



# Maximize Control on the Floor

## Here's How:

The OnTrack® Manufacturing Execution System from Portico gives you the information you need to make the right decisions at the right time, so you'll be informed, empowered, and in control.

## Real-time Visibility Means Greater Control

OnTrack electronically monitors floor activity in real time and gathers data on specific orders, machines, and operators. So at all times, you have a complete and accurate view of every order and your entire factory floor. You can identify opportunities to cut manufacturing cycle times, reduce WIP, and make other improvements. Plus, real-time alarms alert workers and managers when a machine goes down or an order falls behind, so you become immediately aware of a problem in process.

## Process Enforcement For Smoother Workflow

Acting as your central control system, OnTrack enforces structure and discipline on the factory floor, ensuring that the proper process and material flow is followed. OnTrack routes work in process only to the locations capable of performing the work and prevents new orders from entering the system until materials and labor are available. OnTrack manages the proper operation sequence, reducing costs associated with work-in-process (WIP) inventory and re-work.

## Fast, Accurate, Reliable Communication

With OnTrack, operators receive electronic instructions that are always up-to-date, available, and easily accessed. This drastically reduces the need to manage paperwork on the factory floor. The electronic display also eliminates time wasted by employees tracking down lost or misplaced paperwork – they'll always have the information they need to do it right the first time.

## Information for Continuous Improvement

OnTrack delivers the information you need to continuously improve your manufacturing process. OnTrack automatically associates captured quality information with the serialized end item or lot being produced. Data captures occur in real time, so you can quickly identify the source of a problem and fix it, improving productivity and increasing overall process control.

OnTrack from Portico delivers the tools, information, reliability, and flexibility you need to achieve more control of the manufacturing process.

Learn about all the ways OnTrack helps you achieve better control of the floor! Call (630) 717-6270, today for more information or visit our website at [www.PorticoTechPartners.com](http://www.PorticoTechPartners.com).

Portico Technology Partners  
Phone: 630.717.6270  
[www.PorticoTechPartners.com](http://www.PorticoTechPartners.com)

# Maximize Control on the Floor With Real-Time Visibility

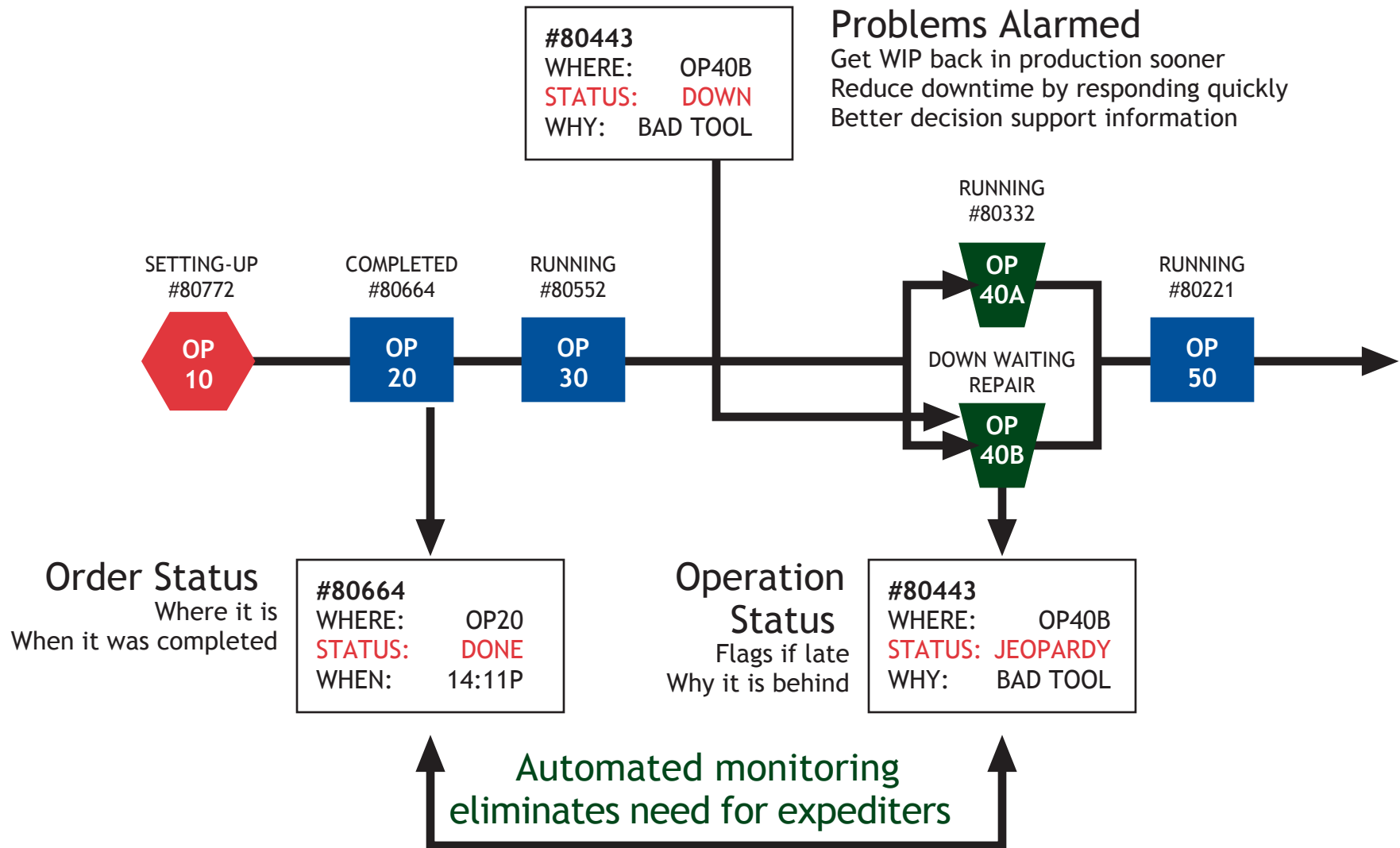

OP = Operation